



**SENSOR**  
AUTOMATIC

**ADS**  
«Tilt»

Ⓓ Bedienungsanleitung

3-14

ⒼⒷ Operating instructions

15-26

**Laserliner**<sup>®</sup>  
Innovation in Tools

# Titanium

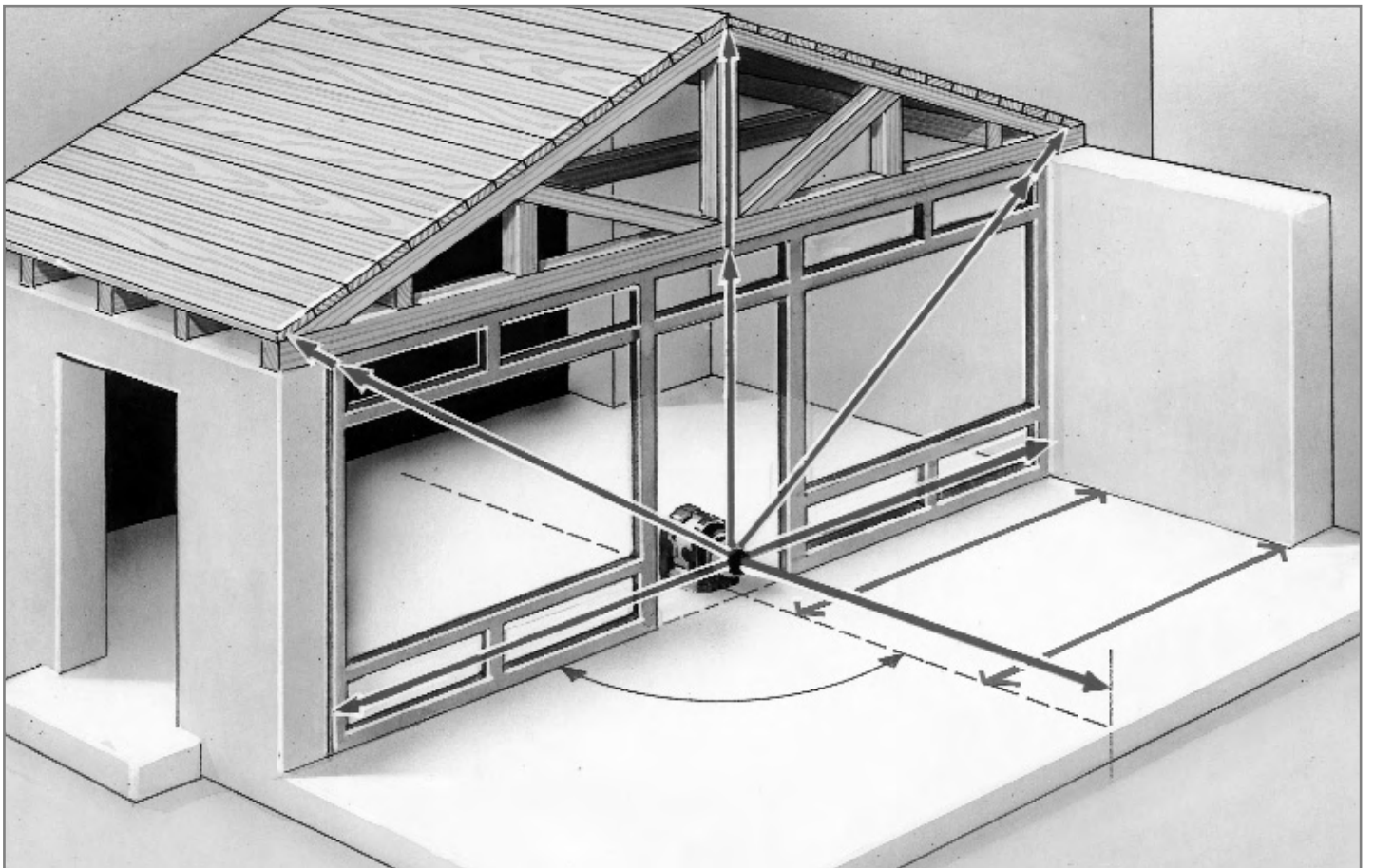
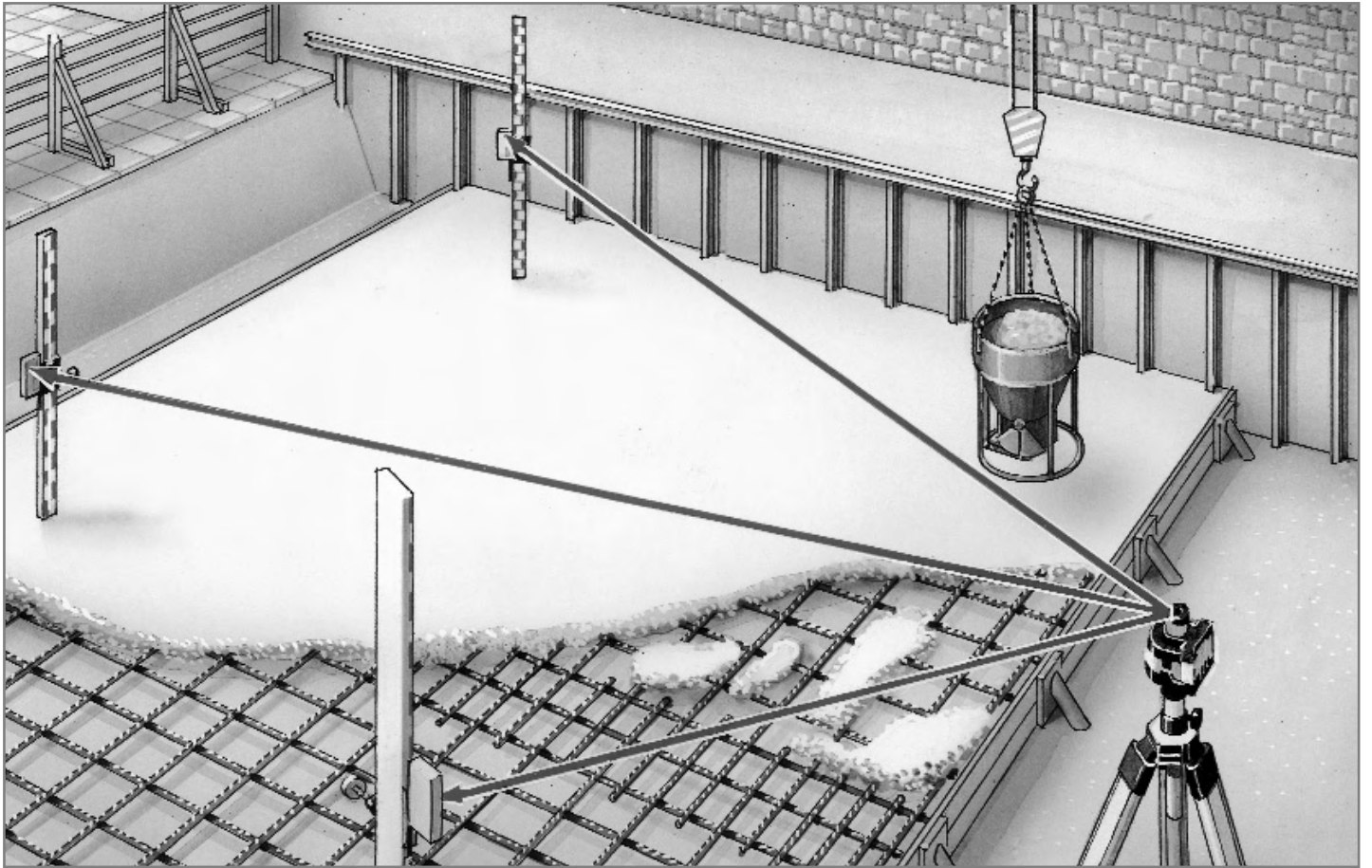

## Professional rotary laser of extremely rugged design. Horizontal and vertical levelling even under the toughest conditions

Automatic self-levelling through electronic vials and servomotors assisted by temperature stable sensors, horizontal and vertical. This unit is equipped with all important laser functions and due to the extreme rugged housing works reliable even under toughest conditions. Dust- and waterproof IP66, precision 1 mm / 10 m, self-levelling range 5 °. Horizontal slopes can be adjusted. The included remote control can control all functions. Titanium Red Laser Class 2.

The green laser of the Titanium Green is much more visible than the red. This allows applications over longer distances and working under very bright ambient light conditions. Titanium Green Laser Class 3R.

### General safety instructions

**Caution:** Do not look directly into the beam. Lasers must be kept out of reach of children. Never intentionally aim the device at people. This is a quality laser measuring device and is 100% factory adjusted within the stated tolerance. For reasons of product liability,



Laser light !  
Do not stare into the  
beam or view directly  
with magnifiers.  
Class 3R laser  
EN60825-1:2003-10

we must also draw your attention to the following: Regularly check the calibration before use, after transport and after extended periods of storage. We also wish to point out that absolute calibration is only possible in a specialist workshop. Calibration by yourself is only approximate and the accuracy of the calibration will depend on the care with which you proceed.

#### Note:

This product is a precision instrument that must be handled and treated with care. Avoid shocks and impact. Always keep and carry in the case! Switch laser off. For cleaning, use a soft cloth and glass cleaner.

### Warranty

The warranty period is 2 years from the date of purchase. The warranty covers all material or manufacturing defects occurring during this time. The following are excluded from warranty: Damage due to improper use (e.g. operation with wrong type of current/voltage, connection to unsuitable power source, fall onto hard surface, etc.) or improper storage, normal wear and tear, and defects which only insignificantly impair the value or suitability for use. Any tampering by unauthorised persons will render this warranty void. In the event that you need to claim warranty, please take the complete device together with all information and the invoice to one of our dealers or send it in to Umarex-Laserliner.

# Titanium

## **SENSOR** Sensor Automatic AUTOMATIC

The Titanium is of the self-levelling kind. After it has been put in the required basic position, fine adjustment is being effected automatically. Horizontal and vertical orthogonal adjustments are effected by the self-levelling system (SLS), while the X-, Y- and the Z-axis are scanned by two electronic measuring sensors. The working angle is  $\pm 5^\circ$ .

### **ADS** Anti-Drift-System (ADS)

The Anti-drift system (ADS) prevents mismeasurements. Its principle of function: 30 seconds after ADS has been activated, the laser is permanently being checked for its correct adjustment. In case the instrument has been moved by external influences or the laser has lost its frequency, the system switches itself automatically off and the "tilt"-LED shows a permanent light. After the instrument has been switched on, the ADS is not active. In order to protect the instrument from position changes caused by external influences, the ADS has to be activated by pressing the push-button "tilt" (J). Should the instrument be moved by external influences, then the laser is switched off and the "tilt"-LED (K) shows a permanent light. The instrument has to be switched off and -on again if work is to be commenced. This is a simple and reliable prevention of misreadings.

**Attention:** The ADS-function will switch on the control of the laser 10 sec. after the laser has completely been levelled (adjustment phase). Tilt display (K) emits long blink signals during the adjustment phase and short blink signals when ADS is activated.

### ADS-function:

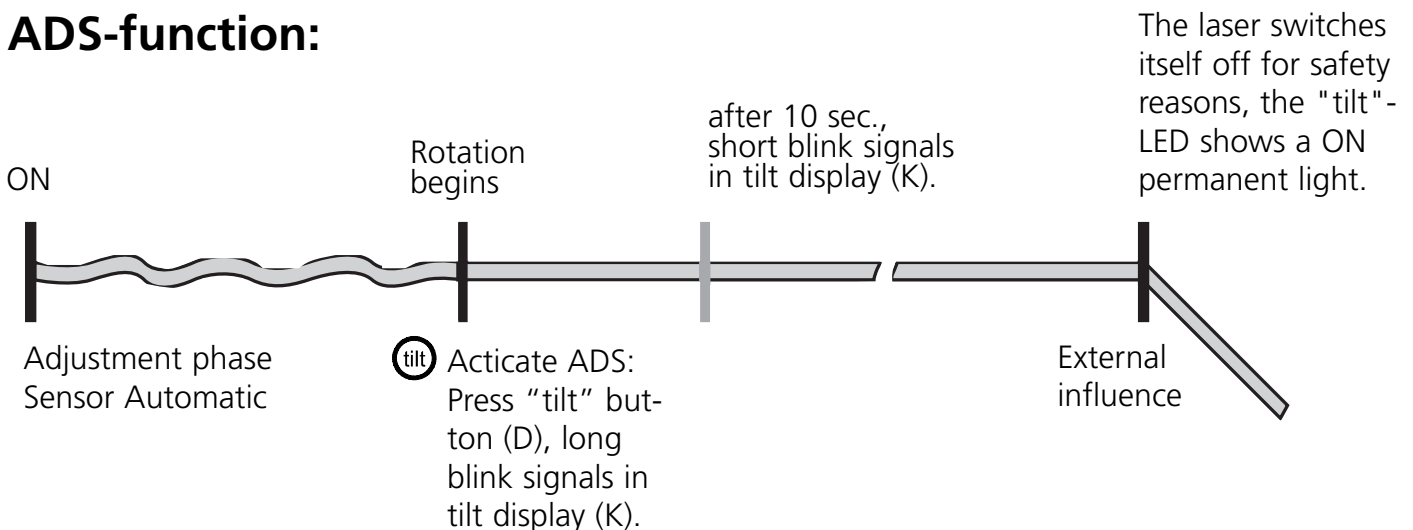

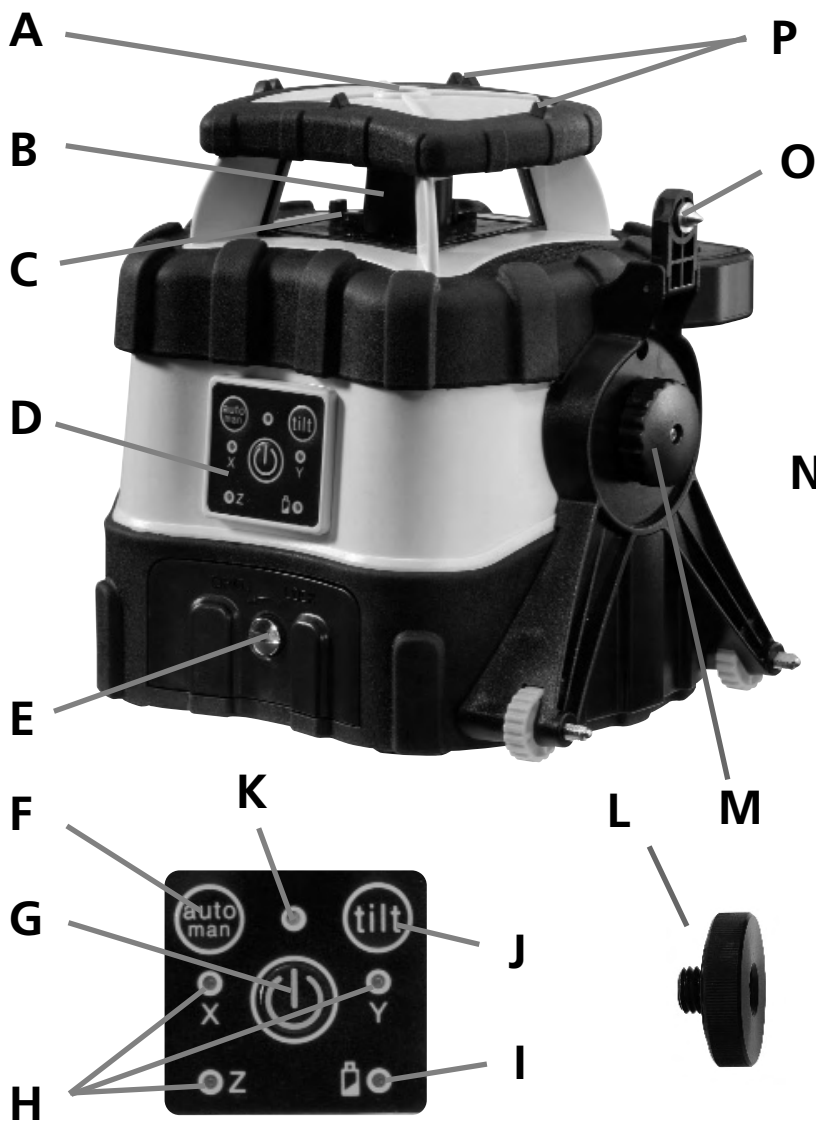

Vertical operation

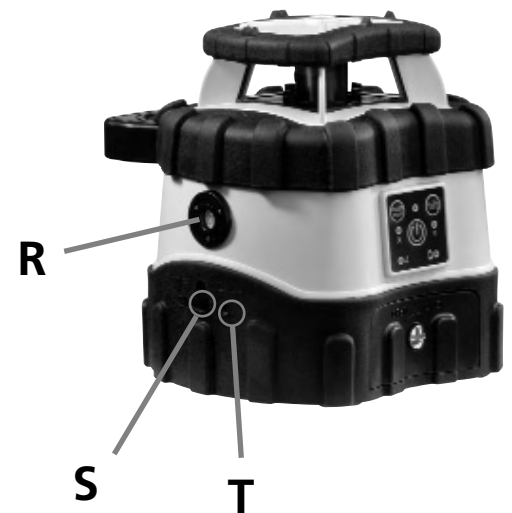
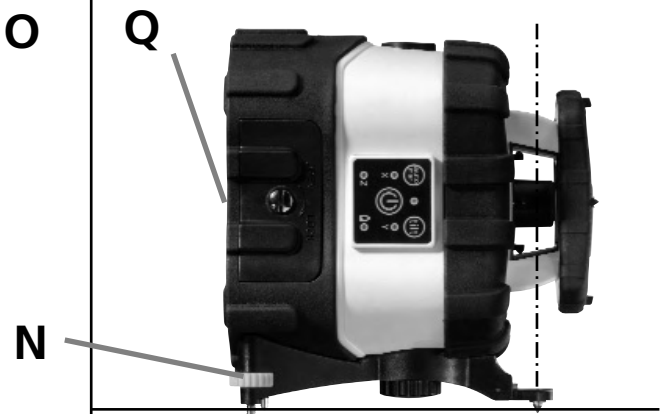

- |   |  |
|---|--|
| <b>A</b> Reference laser outlet                 | <b>K</b> Tilt display                          |
| <b>B</b> Prism head                             | <b>L</b> 5/8 " tripod adapter for vertical use |
| <b>C</b> Receiver diode for remote control (4x) | <b>M</b> Vertical holder (screw adjustment)    |
| <b>D</b> Control panel                          | <b>N</b> Adjusting screws                      |
| <b>E</b> Battery compartment                    | <b>O</b> Centric point (with hinge)            |
| <b>F</b> auto/man button                        | <b>P</b> Quick sighting                        |
| <b>G</b> ON / OFF button                        | <b>Q</b> 5/8" thread                           |
| <b>H</b> Anzeigen X, Y und Z-Achsen             | <b>R</b> Vertical vial for pre-adjustment      |
| <b>I</b> Operating / Battery display            | <b>S</b> Charger socket (DC 6V)                |
| <b>J</b> Tilt button                            | <b>T</b> Battery charge display                |

## Key pads and symbols LCD-Display

**Commader 50**

**SensoCommander**

**SensoLite**

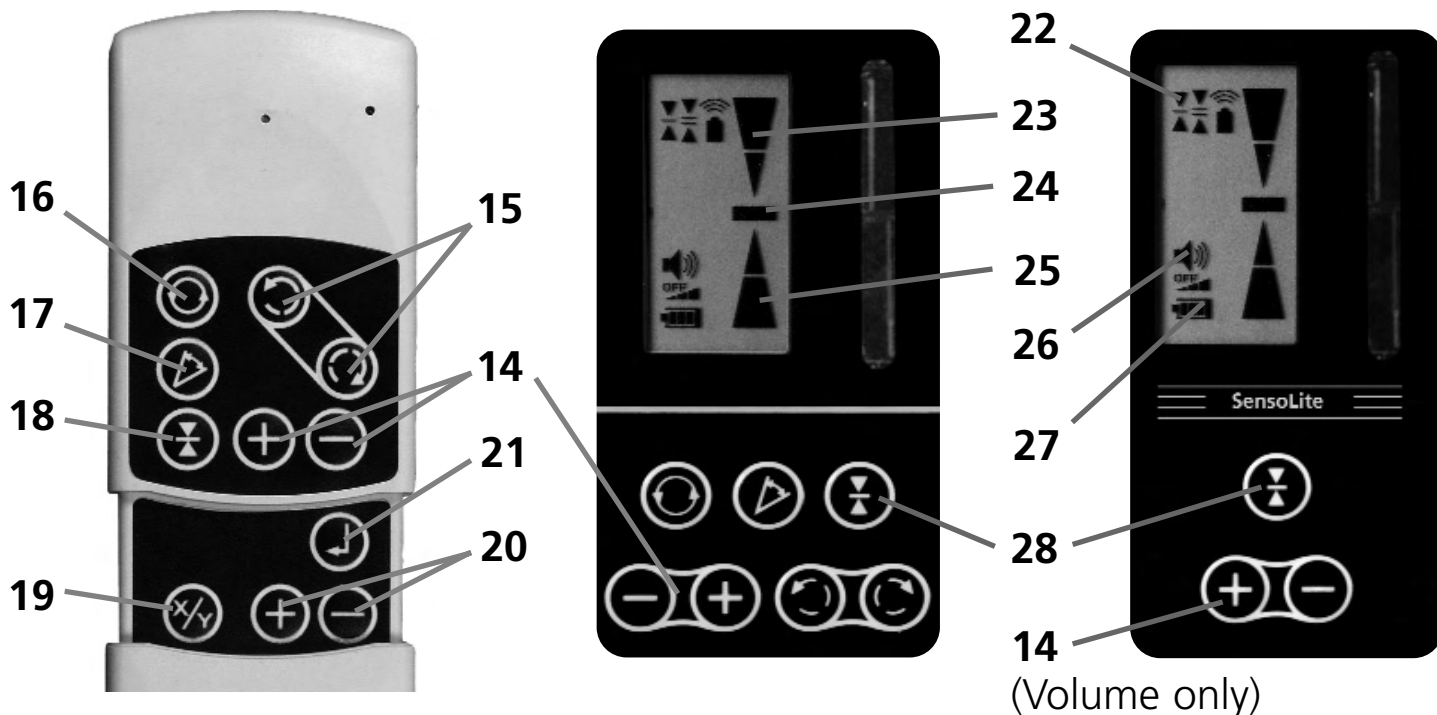

**14** Speed / Angle range / Adjusting axis at auto/man mode / Volume at Hand receiver mode

**15** Position

**16** Rotations-Modus

**17** Scan mode

**18** Hand receiver mode

**19** Calibration mode: Switch X-, Y,-axis

**20** Calibration mode: Adjusting axis

**21** Calibration mode: Saving the new calibration.

**22** Display measuring range selection



**23** Hand receiver above laser level

**24** Precisely on laser level

**25** Hand receiver below laser level

**26** Acoustic signal display

**27** Low battery display

**28** Hand receiver mode /  
Switch: Precision range   
Free-hand range 

**Note:**

The laser receiver has two tolerance settings: Precision and free-hand setting. On the SensoCommander 120, the settings are indicated by LEDs: precision setting: green; free-hand setting: orange.

# Titanium

## Operation of the Titanium

### Charging the batteries

- Before using the device, fully charge the batteries
- Open the battery compartment (E), insert the batteries and connect the plugs to the sockets. The plugs fit in the sockets in one position only (see pictures on right). Reclose the battery compartment.
- Connect the battery charger/mains unit to a mains source and plug into the socket (S). Please only use the charger/mains unit supplied with the device. If a different one is used, the warranty will become void.
- The device can also be operated with standard alkali batteries (4 x type D). Insert the batteries as shown by the installation symbols. Ensure the polarity is correct.
- If the LED (T) blinks constantly, either the batteries must be exchanged or recharged.

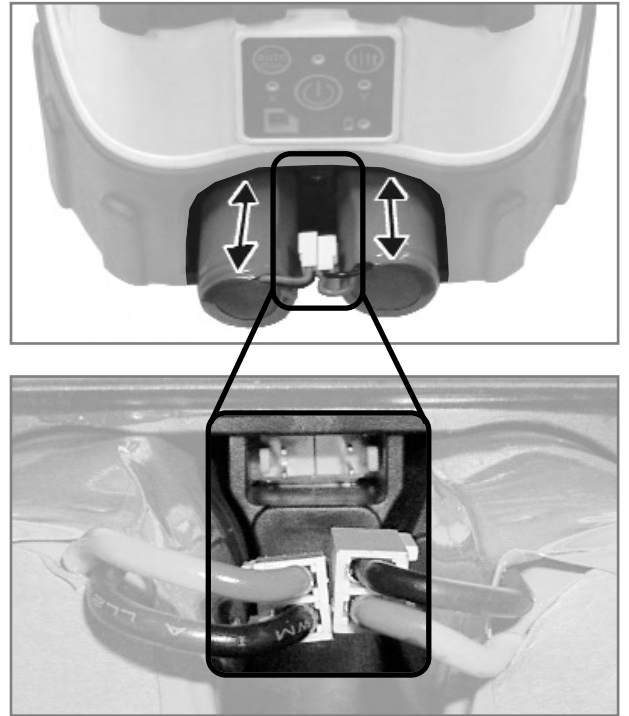

### Insertion of batteries in the SensoLite and SensoCommander:

- Remove the battery cover (9) and insert the batteries as shown by the installation symbol, ensuring that the polarity is correct. Then replace the cover.
- To extend battery life, the receiver switches off automatically after about 5 minutes if not used.

#### Note:

Do not expose batteries to excessive heat such as sunshine, fire, etc. Dry batteries must not be recharged. Used batteries must not be disposed of as household waste. Please take them to a collection point for used batteries or for special waste. Ask your local authority for further details. Batteries with the recycling symbol can also be returned to our dealerships or to our Technical Service.



## Horizontal and vertical use

### Setting up:





- Horizontal: Position the device on a level surface or on a tripod.
- Vertical - fix vertical holder (M), unfold centric point (O) and position unit in vertical mode. Pre-adjust unit with vertical vial (R) and adjusting screws (N). The sensor then adjusts the unit automatically. For use on tripods remove vertical holder (M) and screw-on tripod holder (L).
- PRESS THE "ON/OFF" SWITCH (G).
- The device automatically levels itself within a range of  $\pm 5^\circ$ . When levelling has been completed, the laser rotates at maximum speed. The operating display (I) is lit up and the rotary laser is in the hand receiver mode. Switch on the laser receiver with the button (18), the button (18) and the laser beam is recognised.

**Note:** If the device is too far off the horizontal (more than  $5^\circ$ ), a warning signal will sound and the rotor head will stop. In this case, the device must be repositioned on a more level surface.

### Turn the vertical plane:

- In vertical use the laser plane can exactly be turned. Press auto/man button (F).
- The vertical plane ( $\pm 5^\circ$ ) can now be changed with the Commander 50 or SensoCommander. To do this press buttons (14)  

### Manual Slope function:

- The Sensor-Automatic adjusts the X and Y axes. However, if it is intended to project an incline, Sensor-Automatic must be switched off.
- To project an incline, press the auto/man (F) button. The X axis can now be adjusted, and the X axis display (H) lights up. To adjust the inclination of the Y axis, press the tilt button (J); the Y axis display (H) lights up.  
- Adjustment of the X and Y axes is done using the Commander 50 or SensoCommander. To do this, press buttons (15).  

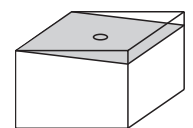

In 1 plane

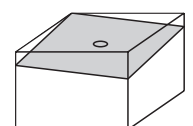

In 2 planes

# Titanium

## Laser modes

The following modes can be controlled with the Commander 50 up to a maximum distance of 50 m. Open battery compartment and insert battery according to picture on the right, ensure polarity is correct and close battery compartment. The rotating laser can also be controlled with the SensoCommander.

### **Point mode**

To establish point mode, press button (16) repeatedly until the laser no longer rotates. The laser can then be precisely positioned to the measuring level with the direction buttons (15).



### **Rotary mode**

Use button (16) to set the desired speed of rotation: 0, 150, 500 rpm.

### **Scan mode**

Button (17) can be used to activate and set an intensive light segment with one of 4 different widths. The segment can be positioned with the direction buttons (15).



### **Hand receiver mode**

Working with the optional laser receiver: Switch on the SensoLite laser receiver with the button (18).

With the Commander 50 and SensoCommander you could set the maximum rotary speed, 500 rpm. It is able to detect the laser beam at a great distance now. Move the SensoLite up and down through the laser beam until the middle indicator (24) appears. Mark the measured height at the perimeter marking groove.

**SpotLite Marking:** The projected light beam at the height of the laser beam simplifies precise marking and prevents parallax error.

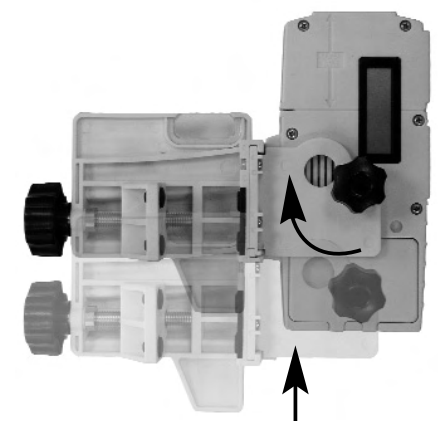

## Universal mount (optional):

The laser receiver can be installed on levelling staffs with the aid of the universal mount. The Flexi measuring staff (Art. No. 080.50) is always recommended when measuring from floor heights. It also allows you to determine heights directly without any need for calculation.

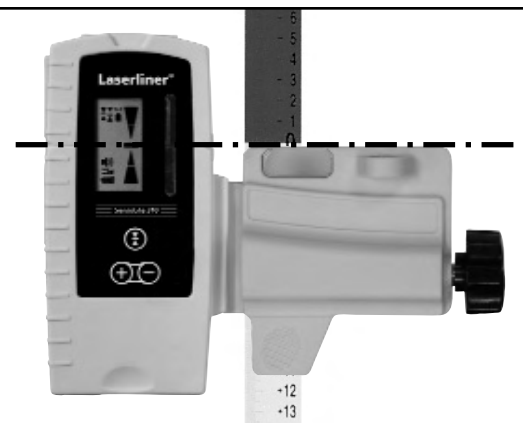

## Titanium Green (Laser class 3R)

The distance at which a laser is visible to the naked eye depends on its colour i.e. wavelength. This is because of the human eye's physiology – green appears brighter to us than red. Depending on ambient light, green lasers are therefore many times more visible than red lasers; in indoor areas this is as much as 12 times brighter. This permits applications on dark surfaces, over longer distances and work in very bright ambient light. A red laser with a 635 nm wavelength is used as a reference value for brightness differentiation.

In contrast to red lasers, green laser light can only be produced indirectly. This is a source of potential characteristic fluctuations:

- The optimal operating temperature is 20°C. Outside of the operating temperature range of 0 ... 45°C green lasers become darker. **IMPORTANT:** Allow the unit enough time to adapt to the ambient temperature before switching the unit on.
- Laser brightness may vary somewhat from one unit to another. This is a natural phenomena and excluded from warranty claims.
- Green Laser will only work with certain Receivers. The maximum range of the Receiver is shorter, please refer to technical details.

## Additional safety recommendations for Laser Class 3R.

- The laser must never be allowed to shine into people's eyes, whether intentionally or accidentally.
- Always keep the eyes at least 15 cm away from the reflection of the laser beam on a surface.
- Never point the laser at reflecting surfaces.
- Never look at the laser beam through optical devices (magnifying glass, microscope, binoculars, ...).
- If possible, shield off the pathway of the laser beam, e.g. by screens or other devices.
- Mark off the work area by cordons and warning signs.
- If possible, the laser beam should not run at eye level (1.60 m ... 1.90 m).

# Titanium

## Preparing the calibration check

It is possible for you to check the calibration of the laser. To do this, position the device **midway** between 2 walls, which must be at least 5 metres apart. Switch the device on. The best calibration results are achieved if the device is mounted on a tripod.

1. Mark point A1 on the wall. (Use spot mode.)
2. Turn the device through 180° and mark point A2. You now have a horizontal reference between points A1 and A2.

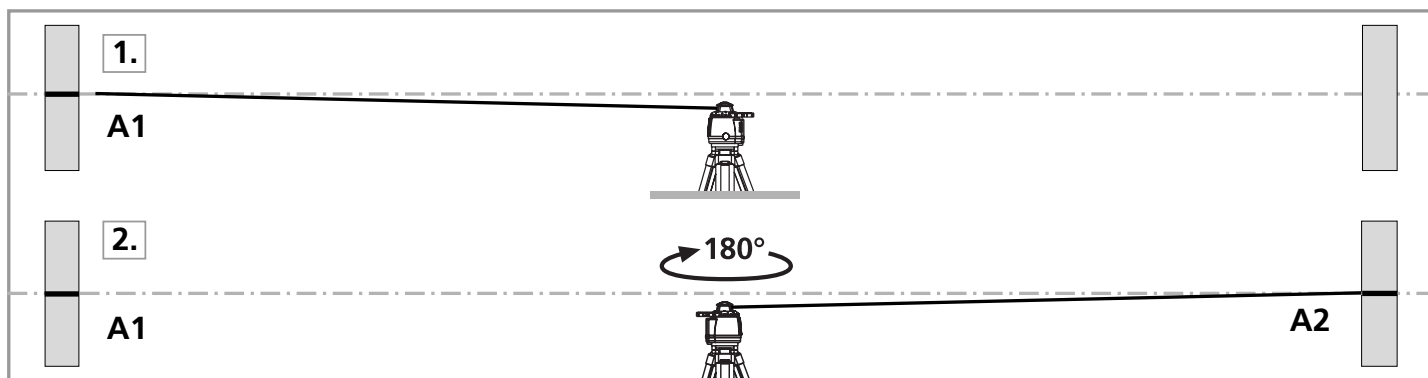

## Performing the calibration check:

3. Position the device as near as possible to the wall at the height of point A1. Now adjust the device in the X axis.
4. Turn the device through 180° and mark point A3. The difference between points A2 and A3 is the tolerance for the X axis.
5. To check the Y and Z axis, repeat steps 3 and 4.

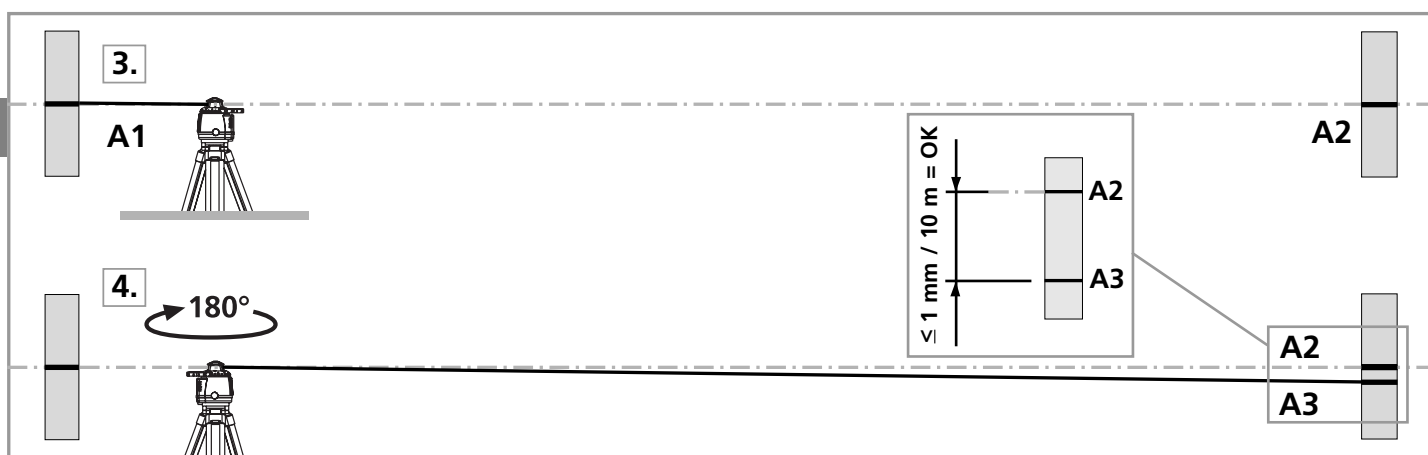

### Note:

If points A2 and A3 are more than 1 mm / 10 m apart on either the X, Y or Z axis, the device is in need of calibration. Contact your authorised dealer or else the UMAREX-LASERLINER Service Department.



## Recalibration

1. During calibration, pay attention to the alignment of the DuraMax and the displays for the X and Y axes (H). Always calibrate both axes. You can switch between axes with button (19) of the additional remote control. 



Alternatively the X- and Y-Axis can be changed with the button  (SensoCommander).

In vertical mode the Z-Axis is automatically switched on.

2. **Set the device to calibration mode:**

Switch off the Titanium, and then, with the auto/man button (F) depressed, switch on again, briefly press ON/OFF button (G). Keep the auto/man button (F) depressed until the tilt display (K) lights up. When this happens, the auto/man button (F) can be released.  

3. **Correcting calibration:**

Using the buttons (20) of the Commander 50 or the buttons (15) of the SensoCommander, move the laser from its present position to the height of reference point A2.   Mit

4. **Ending calibration:**

Cancel: By switching off the DuraMax, the entire calibration is rejected and the previous status restored. 

Save: The new calibration can be saved by pressing button (21) of the additional remote control or SensoCommander. 

Alternatively the new calibration can be saved with the button  (SensoCommander).

### Note:

Regularly check the calibration before use, after transport and after extended periods of storage. Always make sure to control all axes.

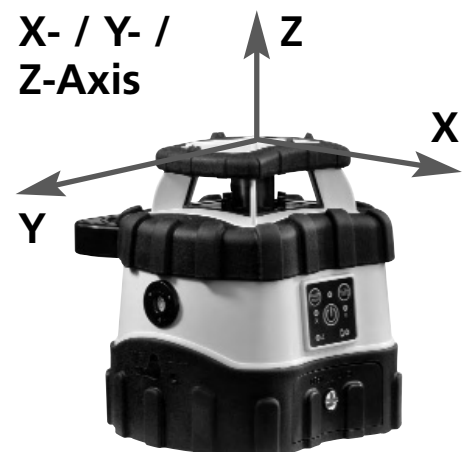

# Titanium (Subject to technical alterations)

<b>Titanium red / green</b>	
Self-levelling range	$\pm 5^\circ$
Precision	$\pm 1 \text{ mm} / 10 \text{ m}$
Horizontal / vertical levelling	Automatic with electronic sensors and servo motors
Self-levelling alignment time	ca. 30 s
Vertical reference beams	$90^\circ$ to rotation plane
Rotation speed	0, 150, 500 RPM
Remote control	Infrared IR
Laser wavelengths, green / red	635 nm / 532 nm
Laser class red / green	2 / 3R (EN60825-1:2003-10)
Laser output rating	$< 1 \text{ mW} / < 5 \text{ mW}$
Protection class	IP 66
Rechargeable battery life red / green	approx. 24 h / 16 h
Non-rechargeable battery life red / green	approx. 35 h / 24 h (4 x type D)
Battery recharging time	approx. 14 h
Working temperature range red / green	$-10^\circ\text{C} \dots +50^\circ\text{C} / 0^\circ\text{C} \dots +45^\circ\text{C}$
Weight	3,3 kg
<b>Remote control, laser receiver (optional)</b>	
Batteries: Commander 50 / SensoLite 310 / SensoCommander 310 SensoLite 300 / SensoLite 120	1 x 9V Block / 1 x 9V Block / 1 x 9V Block 4 x type AA / 2 x type AAA
Battery life	approx. 70 h (Mischbetrieb)
Remote control range Commander 50 SensoCommander 310	max. 50 m max. 15 m
Laser reception range SensoLite 310 / SensoLite 120 SensoLite 300 / SensoCommander 310	Titanium red 310 m / 120 m 300 m / 310 m
Laser reception range SensoLite 310 / SensoLite 120	Titanium green 200 m / 120 m
Temperature range, operating / storage	$-10^\circ\text{C} \dots + 50^\circ\text{C} / -10^\circ\text{C} \dots + 70^\circ\text{C}$

- D** Zubehör (optional)
- GB** Accessories (optional)
- NL** Accessoires (optioneel)
- DK** Tilbehør (flere typer)
- F** Accessoires (en option)

- E** Accesorios (opcional)
- I** Accessori (optional)
- PL** Akcesoria (opcja)
- FIN** Lisämahdollisuuksia valinnaisvarusteilla
- P** Acessórios (opcional)

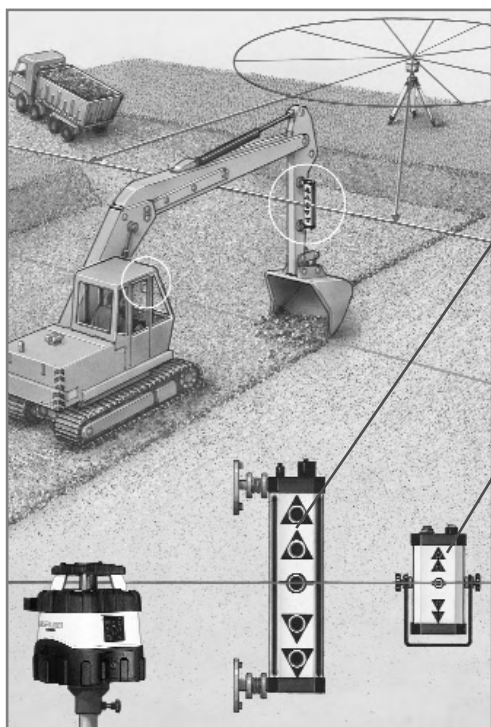

Art.-Nr: 035.00.A  
(Titanium Green)

Art.-Nr: 035.01  
(Titanium Green)

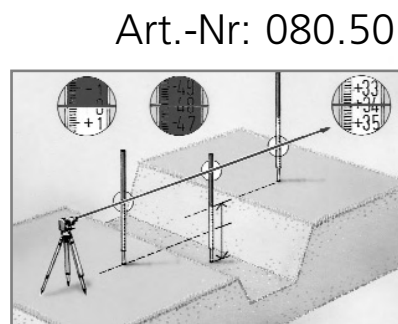

Art.-Nr: 080.50

Art.-Nr: 080.33



Art.-Nr: 075.108 (8m)  
Art.-Nr: 075.105 (5m)

